

STRAIGHT PLUG CLAMP TYPE

R214.009.133

CABLE 3.8/95 S

Series : SMZ

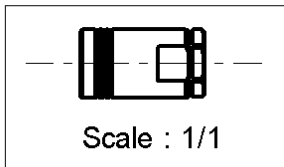
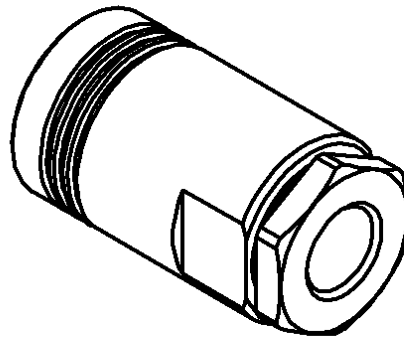
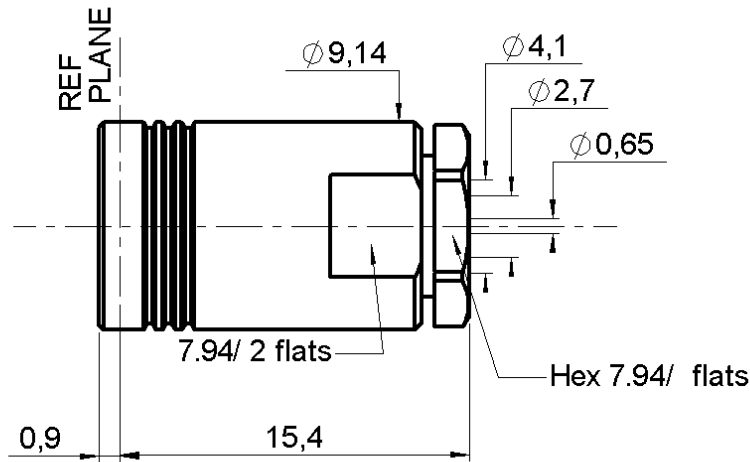

All dimensions are in mm.



COMPONENTS	MATERIALS	PLATINGS (µm)
BODY	BRASS	GOLD 0.2 OVER NICKEL 2
CENTER CONTACT	BERYLLIUM COPPER	GOLD 1.3 OVER NICKEL 2.54 OVER COPPER
OUTER CONTACT	BERYLLIUM COPPER	3
INSULATOR	PTFE	GOLD 0.5 OVER NICKEL 2
GASKET	-	
OTHERS PARTS	BRASS	
-	-	GOLD 0.2 OVER NICKEL 2
-	-	-
-	-	-

Issue : 0046 B

In the effort to improve our products, we reserve the right to make changes judged to be necessary.



STRAIGHT PLUG CLAMP TYPE

R214.009.133

CABLE 3.8/95 S

Series : SMZ

PACKAGING

Standard	Unit	Other
100	'W' option	Contact us

SPECIFICATION

CABLE ASSEMBLY

ELECTRICAL CHARACTERISTICS

Stripping	a	b	c	d	e	f
mm	2.00	1.00	4.00	3.20	2.00	0.00

Impedance		75 Ω
Frequency		0-2.4 GHz
VSWR	1.20 +	0.000 x F(GHz) Maxi
Insertion loss		0.12 √F(GHz) dB Maxi
RF leakage	- (60 - F(GHz)) dB mini
Voltage rating		500 Veff Maxi
Dielectric withstanding voltage		1500 Veff mini
Insulation resistance		500 MΩ mini

Assembly instruction :

Recommended cable(s)
 RG 180 BU
 RG 195 AU

Cable retention

- pull off **144** N mini
- torque **NA** N.cm

MECHANICAL CHARACTERISTICS

TOOLING

Center contact retention		
Axial force – Mating end	10	N mini
Axial force – Opposite end	10	N mini
Torque	NA	N.cm mini

Part Number	Description	Hexagon
.	.	.

Recommended torque		
Mating	NA	N.cm
Panel nut	NA	N.cm
Clamp nut	100	N.cm
A/F clamp nut	7.940	mm

OTHERS CHARACTERISTICS

Mating life	250	Cycles mini
Weight	0.000	g

ENVIRONMENTAL

Operating temperature	-55/+155	° C
Hermetic seal	NA	Atm.cm3/s
Panel leakage	NA	

Issue : 0046 B

In the effort to improve our products, we reserve the right to make changes judged to be necessary.



STRAIGHT PLUG CLAMP TYPE

R214.009.133

CABLE 3.8/95 S

Series : SMZ

COMPONENTS

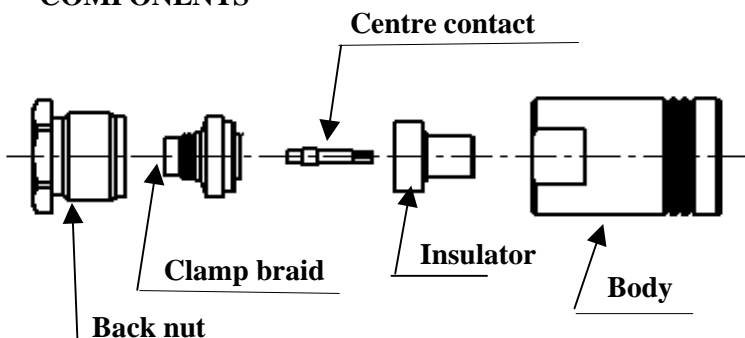

STRIPPING DIMENSIONS

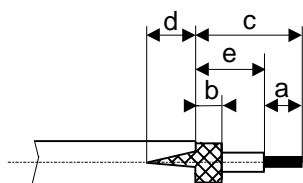

1

Mount the clamp nut
Strip off the cable then make 2 slits in the sheath 180° apart longitudinally

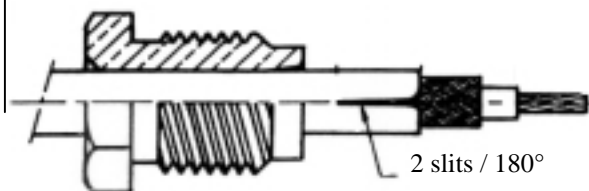

3

Screw the cable assembly into the connector body
Recommended coupling torque (see connector TDS)

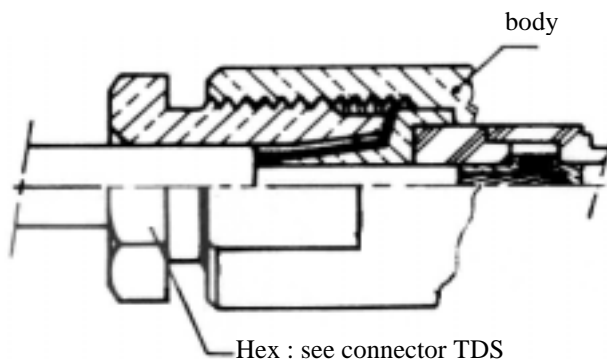

2

Mount the braid-clamp
Trim braid to Ø of the braid-clamp
Solder the centre contact
Mount the insulator

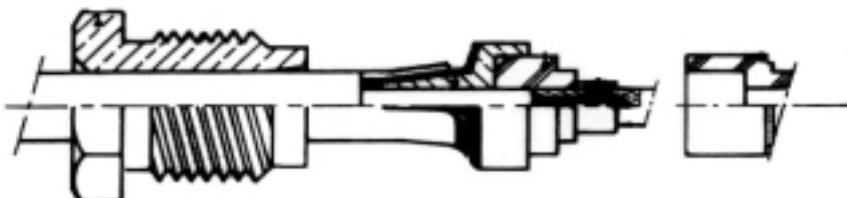

Issue : 0046 B

In the effort to improve our products, we reserve the right to make changes judged to be necessary.

